

# MERCER

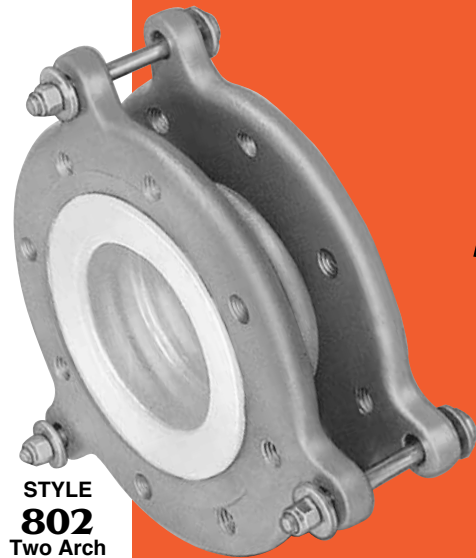

# 800

## Teflon® Expansion Joints



STYLE  
**802**  
Two Arch  
Expansion  
Joint

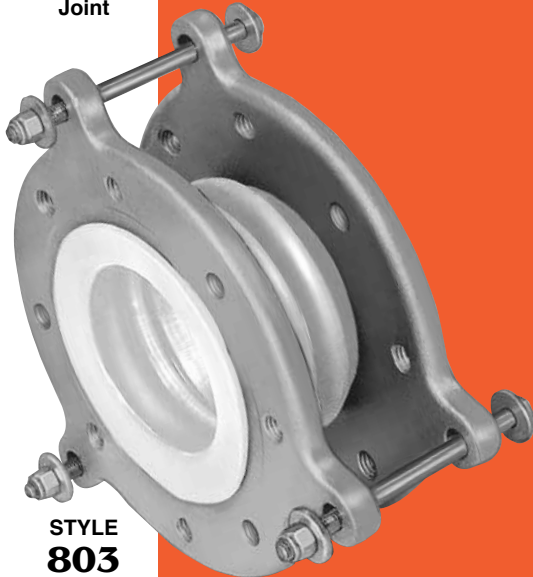

STYLE  
**803**  
Three Arch  
Expansion  
Joint

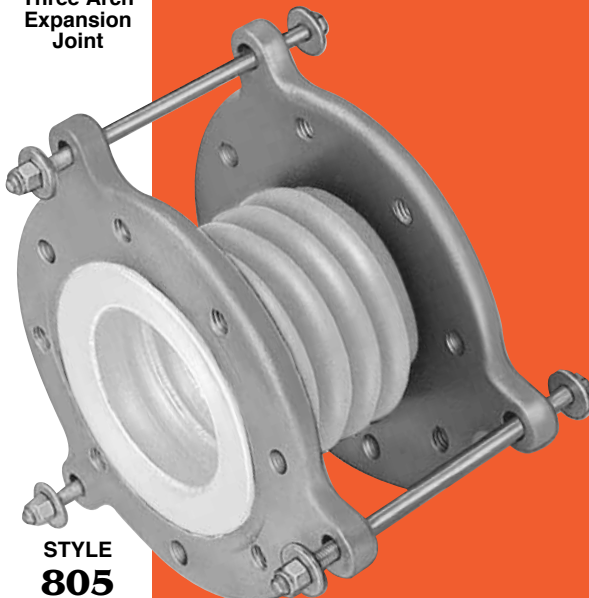

STYLE  
**805**  
Five Arch  
Expansion  
Joint

**MERCER Series 800 PTFE Teflon® Expansion Joints are the Sure and Economical Way to Solve Difficult Expansion and Misalignment**

The Teflon® material is corrosive-proof, chemically inert and does not age. Flexibility and flex cycle life is equally exceptional.

The Teflon® body is formed over the full sealing face of the flanges eliminating the need for separate gaskets. The fluid or gas never contacts the floating flanges.

The Type 800 is manufactured in 2, 3 and 5 arch variations designated 802, 803 and 805. Flexibility and allowable movements increase with the number of arches. Teflon® is ideally suited to the following problems:

- Handling Nitric or Sulfuric acid in mining or plating operations.
- Providing low spring rates and high flexibility to protect fragile FRP, PVC or glass pipe from damage caused by expansion, contraction or ambient vibration.
- Accommodating expansion and contraction in high temperature (to 350°F, 177°C) caustic green, white and black liquor lines in pulp mills.
- Preventing pipe line vibration from damaging glass linings in acid and caustic soda pumps.
- Providing flexibility to prevent flange leaks caused by the minor explosions in lines from Chlorine generators in bleaching plants of paper mills.
- Providing non-contaminating, sterilizable, flexible connectors for the food processing, medical, and chip manufacturing industries.

The standard assembly utilizes high strength carbon steel flanges complete with three restraining bolts. The Teflon® is reinforced externally with stainless steel rings between arches. They are also available with stainless steel flanges and stainless steel hardware. There is a MERCER Series 800 Teflon® Expansion Joint to suit your needs.

**STYLE 802**  
Two Arch Expansion Joint

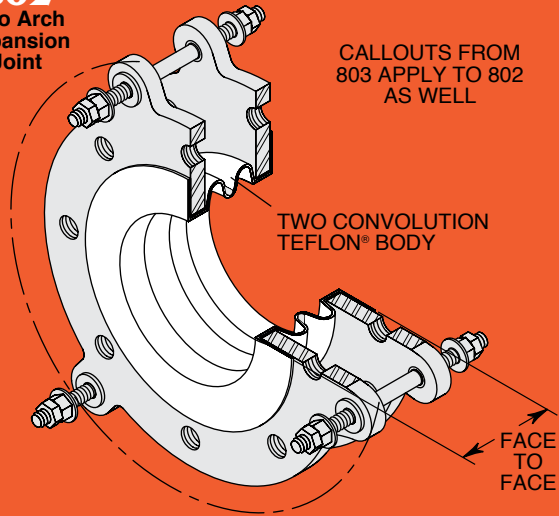

**STYLE 800 SERIES MAXIMUM PRESSURE RATINGS**

Pipe Size in mm	Maximum Pressure Ratings (psig kg/cm <sup>2</sup> ) at							
	50°F 10°C		100°F 38°C		150°F 66°C		200°F 93°C	
	802	803	802	803	802	803	802	803
1 25	180 12.7	150 10.5	135 9.5	100 7.0	100 7.0	75 5.3	90 6.3	70 4.9
1½ 40	180 12.7	150 10.5	135 9.5	100 7.0	100 7.0	75 5.3	90 6.3	70 4.9
2 50	180 12.7	150 10.5	135 9.5	100 7.0	100 7.0	75 5.3	90 6.3	70 4.9
2½ 65	180 12.7	150 10.5	135 9.5	100 7.0	100 7.0	75 5.3	90 6.3	70 4.9
3 80	180 12.7	150 10.5	135 9.5	100 7.0	100 7.0	75 5.3	90 6.3	60 4.2
4 100	150 10.5	150 10.5	125 8.8	100 7.0	100 7.0	75 5.3	85 6.0	70 4.9
5 125	150 10.5	150 10.5	125 8.8	85 6.0	85 6.0	65 4.6	80 5.6	65 4.6
6 150	150 10.5	150 10.5	120 8.4	80 5.6	75 5.3	55 3.9	75 5.3	60 4.2
8 200	150 10.5	150 10.5	115 8.1	75 5.3	70 4.9	45 3.2	65 4.6	50 3.5
10 250	150 10.5	150 10.5	115 8.1	75 5.3	70 4.9	50 3.5	60 4.2	40 2.8
12 300	150 10.5	150 10.5	110 7.7	75 5.3	60 4.2	40 2.8	50 3.5	30 2.1

All joints are full vacuum rated up to 200°F (93°C)

**STYLE 802 DIMENSIONS and ALLOWABLE MOVEMENTS**

Size in mm	Flange Dia. D		Style 802		
	in	mm	Face to Face in mm	Axial ± in mm	Max Misalignment in mm
1 25	6	152	1¾ 35	¼ 6	⅛ 3
1½ 40	6¾	172	1¾ 35	¼ 6	⅛ 3
2 50	8½	206	1¾ 41	¼ 6	⅛ 3
2½ 65	9¾	238	2¼ 57	⅜ 9	⅛ 3
3 80	10	254	2¼ 57	⅜ 9	¼ 6
4 100	11½	286	2½ 67	½ 13	¼ 6
5 125	13	330	3¼ 83	½ 13	¼ 6
6 150	14	356	3¾ 95	½ 13	¼ 6
8 200	16¼	413	4 102	½ 13	¼ 6
10 250	19	483	5¼ 133	½ 13	¼ 6
12 300	22½	572	6 152	½ 13	¼ 6

**STYLE 803**  
Three Arch Expansion Joint

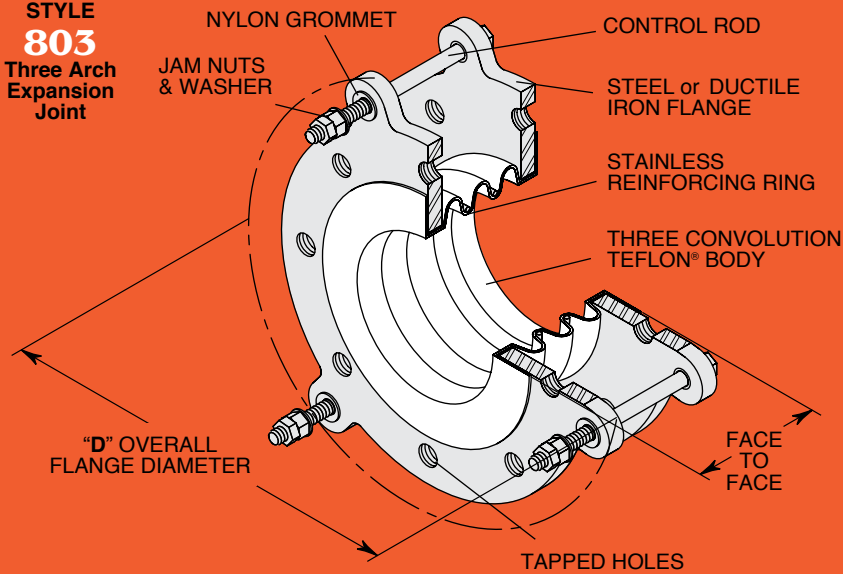

**STYLE 803 DIMENSIONS and ALLOWABLE MOVEMENTS**

Size in mm	Flange Dia. D		Style 803		
	in	mm	Face to Face in mm	Axial ± in mm	Max Misalignment in mm
1 25	6	152	1¾ 44	½ 13	¼ 6
1½ 40	6¾	172	2 51	½ 13	¼ 6
2 50	8½	206	2¾ 70	½ 13	⅜ 9
2½ 65	9¾	238	3¼ 83	¾ 19	⅜ 9
3 80	10	254	3½ 92	¾ 19	½ 13
4 100	11½	286	3½ 92	1 25	½ 13
5 125	13	330	4 102	1 25	½ 13
6 150	14	356	4 102	1 25	⅝ 16
8 200	16¼	413	6 152	1½ 29	⅝ 16
10 250	19	483	7 178	1½ 29	⅝ 16
12 300	22½	572	7¾ 200	1½ 29	⅝ 16

**STYLE 805**  
Five Arch Expansion Joint

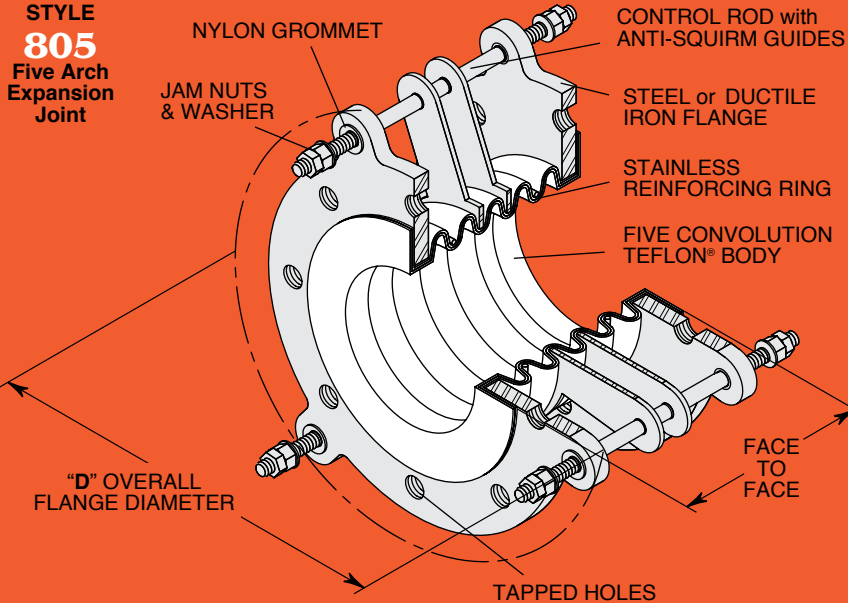

**STYLE 805 DIMENSIONS and ALLOWABLE MOVEMENTS**

Size in mm	Flange Dia. D		Style 805		
	in	mm	Face to Face in mm	Axial ± in mm	Max Misalignment in mm
1 25	6	152	3 76	¾ 19	½ 13
1½ 40	6¾	172	3½ 89	¾ 19	½ 13
2 50	8½	206	4 102	1 25	½ 13
2½ 65	9¾	238	4 102	1 25	½ 13
3 80	10	254	5 127	1 25	½ 13
4 100	11½	286	5¼ 133	1¼ 32	⅝ 16
5 125	13	330	6 152	1¼ 32	⅝ 16
6 150	14	356	6 152	1¼ 32	⅝ 16
8 200	16¼	413	8 203	1¾ 44	⅝ 16
10 250	19	483	8 203	1¾ 44	¾ 19
12 300	22½	572	9 229	2 51	¾ 19



**MERCER RUBBER Co.**

350 Rabro Drive • Hauppauge, NY 11788 • Tel 631-582-1524 • FAX 631-348-0279

Email Info@Mercer-Rubber.com • Website www.Mercer-Rubber.com