



MASON INDUSTRIES, Inc.

Manufacturers of Vibration Control Products

350 Rabro Drive
Hauppauge, NY 11788
631/348-0282
FAX 631/348-0279
Info@Mason-Ind.com

2101 W. Crescent Ave., Suite D
Anaheim, CA 92801
714/535-2727
FAX 714/535-5738
Info@MasonAnaheim.com
www.Mason-Ind.com

JOB NAME _____
CUSTOMER _____
CUSTOMER P.O. _____
MASON M. _____
DWG No. _____

SLF

**3" 75mm
Deflection
100 Series
Spring Mounts**

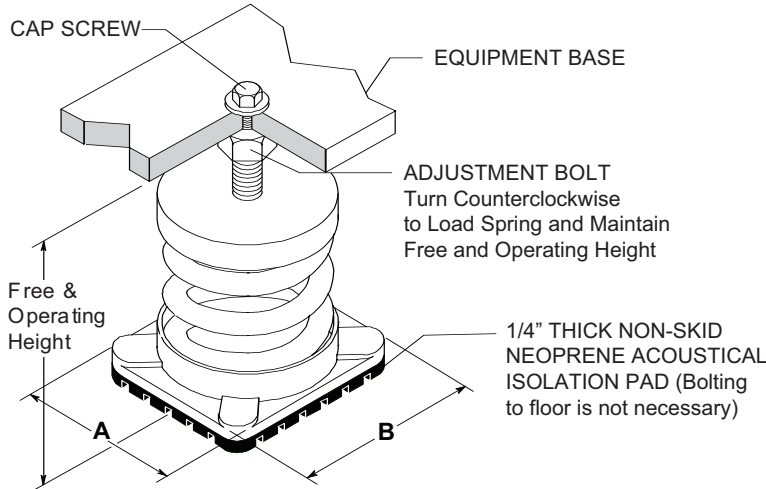

Cap Screw secures Height Saving Bracket (or Equipment Base) to Tapped Concentric Hole in Mounting Adjustment Bolt.

All springs have additional travel to solid equal to 50% of the rated deflection.

Solid Spring Height = Free Height minus 1.5 times Rated Deflection.

OD/OH = Ratio of Spring Outside Diameter to Operating Height = 0.82 - 1.15

Holders for mounts SLF-126 thru SLF-140 are castings.

Holders for mounts SLF-141-143 are steel.

TYPE SLF LOAD RATINGS and DIMENSIONS (inches mm)

Type and Size	Rated Capacity (lbs) (kg)	Rated Defl. (in) (mm)	Mount Constant (lbs/in)(kg/mm)	Spring Color/Stripe	Spring Only		Free & Oper Ht	A		B	Adjustment Bolt AB	Locking Cap Screw CS
					Spring OD	Free Height						
SLF-126	195 88	3.25 83	60 1.06	Purple	33/4 95	63/8 162	8 203	41/4 108	43/4 121	7/8x53/4 x 146	1/2x11/4 x 32	
SLF-127	280 127	3.25 83	85 1.53	Brown	33/4 95	61/2 165	8 203	41/4 108	43/4 121			
SLF-128	390 177	3.25 83	120 2.13	Orange	4 102	61/2 165	8 203	41/2 114	5 127			
SLF-129	520 236	3.25 83	160 2.84	Green	4 102	7 178	8 1/2 216	4 1/2 114	5 127			
SLF-130	710 322	3.25 83	220 3.88	Red	4 1/2 114	7 1/4 184	9 229	5 127	5 1/4 133			
SLF-131	940 426	3.25 83	290 5.13	White	4 1/2 114	7 1/2 191	9 229	5 127	5 1/4 133			
SLF-132	1280 581	3.25 83	395 7.00	Blue	5 127	7 7/8 200	9 1/2 241	5 1/2 140	6 1/2 165			
SLF-133	1770 803	3.25 83	545 9.67	Black	5 1/2 140	9 1/4 235	11 279	6 152	7 178	1 x 6 x 152	1/2x11/4 x 32	
SLF-134	2490 1129	3.25 83	765 13.60	Yellow	5 1/2 140	9 1/4 235	11 279	6 152	7 178			
SLF-135	3300 1497	3.25 83	1000 18.04	Gray	6 152	9 1/2 241	11 1/8 283	6 5/8 168	7 1/2 191			
SLF-136	4500 2041	3.25 83	1370 24.59	Blue/Brown	6 3/4 171	9 3/4 235	11 3/4 298	7 1/2 191	7 1/2 191			
SLF-137	6200 2818	3.25 83	1900 33.88	Blue/Orng	7 3/4 197	10 7/8 276	13 1/4 337	8 1/2 216	8 1/2 216	11/4x8 x 203	5/8x11/2 x 38	
SLF-138	8300 3765	3.25 83	2560 45.36	Blue/Red	7 3/4 197	11 279	13 1/4 337	8 1/2 216	8 1/2 216			
SLF-139	11400 5171	3.25 83	3500 62.30	Blue/White	7 3/4 197	12 1/4 311	14 3/8 365	8 1/2 216	8 1/2 216			
SLF-140	15200 6895	3.25 83	4685 83.07	Blue/Silver	8 3/4 222	12 3/4 324	15 1/2 394	9 1/2 241	9 1/2 241			
SLF-141	20300 9208	3.25 83	6245 110.94	Blue/Gray	9 1/2 241	13 1/2 343	16 1/2 419	10 1/2 267	10 1/2 267	13/4x 8 x 203	3/4x 2 x 51	
SLF-142	28400 12882	3.25 83	8750 155.20	Blue/Green	10 1/4 260	15 381	18 457	11 279	11 279			
SLF-143	39000 17690	3.25 83	12000 213.13	Blue/Yellow	11 279	16 1/8 410	19 483	12 305	12 305			

PLAN VIEW OF MOUNT LOCATIONS

TAG: _____
UNIT: _____



SPECIFIED DEFLECTION

1:	6:
2:	7:
3:	8:
4:	9:
5:	10:
Sets Required:	